

# Cell Type CR17450E-R Specifications

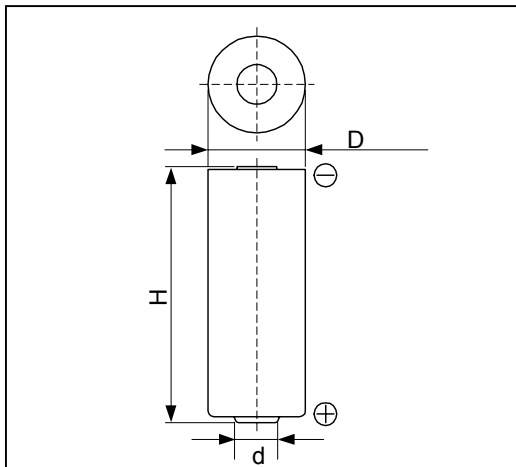

Nominal Capacity* <sup>1</sup>		2200mAh
Nominal Voltage		3V
Standard Discharge Current		5mA
Max. Discharge Current	Continuous* <sup>2</sup>	1000mA
	Pulse* <sup>3</sup>	2500mA
Temperature Range		-40°C ~ 85°C
Weight		22g
Dimensions	D	17.0mm
	H	45.0mm
	d	7mm

\*1 Nominal capacity is determined to an end voltage of 2.0V when the battery is allowed to discharge at a standard current level at 23°C.

\*2 Current value is determined to be the level at which 50% of the nominal capacity is obtained with an end voltage of 2.0V at 23°C.

\*3 Current value for obtaining 1.0V cell voltage when pulse is applied for 15seconds at 50% discharge depth at 23°C.

## Typical Characteristics

Discharge Characteristics of CR17450E-R

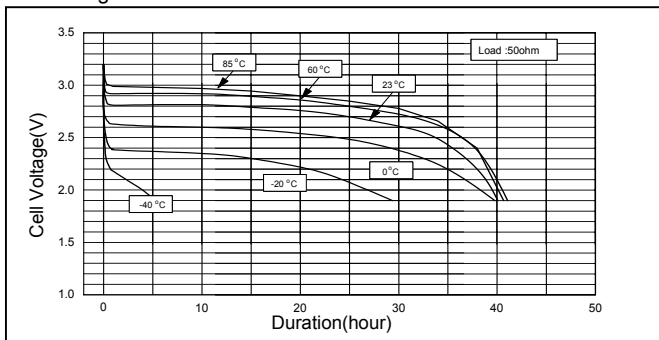

Discharge Characteristics of CR17450E-R

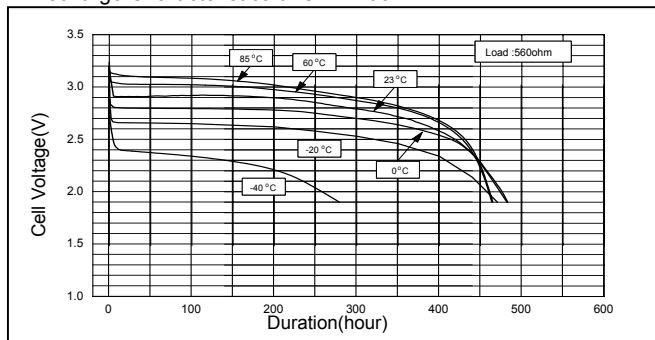

Pulse Discharge Characteristics of CR17450E-R

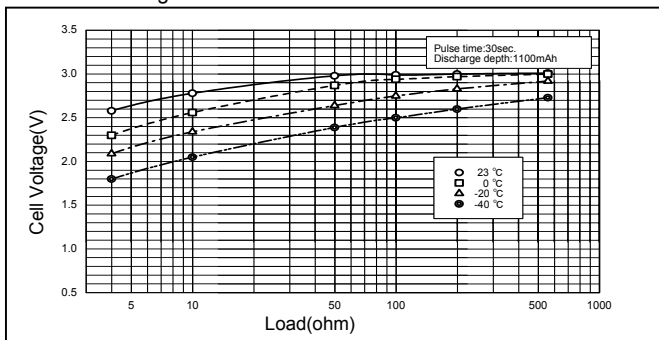

Discharge Load vs. Capacity of CR17450E-R

